

Photologic® Slotted Optical Switches

Types OPB460, OPB470 Series

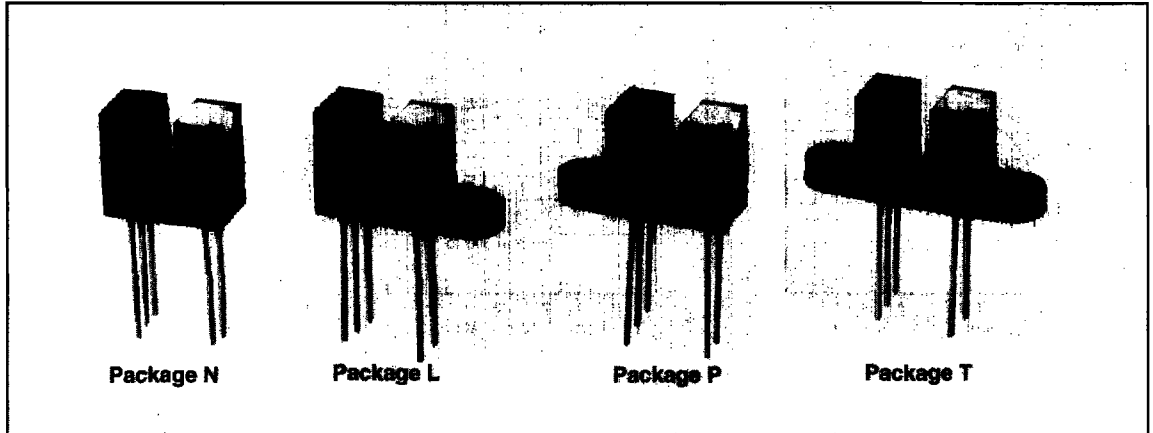

Features

- Choice of mounting configuration
- Choice of aperture
- Choice of output configuration
- Choice of opaque or IR transmissive shell material
- Data rates to 250 kBaud
- 0.320" (8.13 mm) lead spacing for PC board mount
- Low power consumption

Description

The OPB460 and OPB470 series of Photologic® Photo Integrated Circuit Switches provide optimum flexibility for the design engineer. Building from a standard housing with a 0.125" (3.18 mm) wide slot, the user can specify (1) type and polarity of TTL output, (2) discrete shell material, (3) aperture width, and (4) type of mounting configuration.

These devices exhibit stable performance over supply voltages ranging from 4.5 V to 16.0 V and may be specified as buffered or inverted with 10 k Ω pull-up or open collector output. All are TTL/LSTTL compatible and can drive up to 10 TTL loads.

Replaces/Upgrades

OPB960, OPB970 Series.

Absolute Maximum Ratings ($T_A = 25^\circ\text{C}$ unless otherwise noted)

Supply Voltage, V_{CC} (Not to exceed 3 sec.)	18 V
Storage Temperature Range	-40°C to $+85^\circ\text{C}$
Operating Temperature Range	-40°C to $+85^\circ\text{C}$
Lead Soldering Temperature [1/16 inch (1.6 mm) from case for 5 sec. with soldering iron]	$240^\circ\text{C}^{(1)}$
Input Diode Power Dissipation	100 mW ⁽²⁾
Output Photologic® Power Dissipation	90 mW ⁽³⁾
Total Device Power Dissipation	190 mW ⁽⁴⁾
Voltage at Output Lead (Open Collector Output)	35 V
Diode Forward D.C. Current	40 mA
Diode Reverse D.C. Voltage	2 V

Notes:

- (1) RMA flux is recommended. Duration can be extended to 10 sec. max. when flow soldering.
- (2) Derate linearly 1.67 mW/ $^\circ\text{C}$ above 25°C .
- (3) Derate linearly 1.50 mW/ $^\circ\text{C}$ above 25°C .
- (4) Derate linearly 3.17 mW/ $^\circ\text{C}$ above 25°C .
- (5) The OPB460/OPB470 series are terminated with .020" square leads designed for printed circuit board mounting.
- (6) Normal application would be with light source blocked, simulated by $I_F = 0$ mA.
- (7) All parameters tested using pulse technique.

Housing

All housings are an opaque grade of injection-molded plastic to minimize the assembly's sensitivity to ambient radiation, both visible and near-infrared. Discrete shells (exposed on the parallel faces inside the device throat) are either IR transmissive plastic for applications where aperture contamination may occur or opaque plastic for maximum protection against ambient light.

Types OPB460, OPB470 Series

Package N

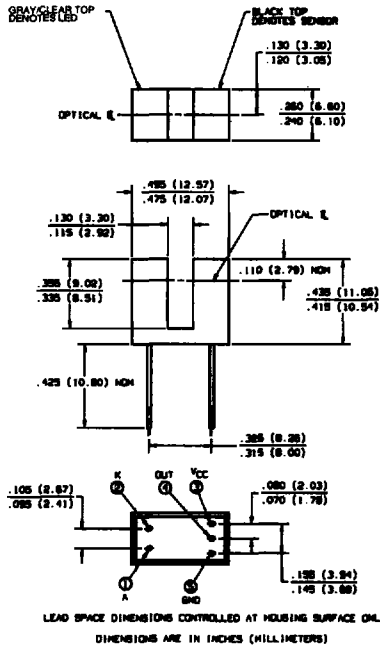

Package T

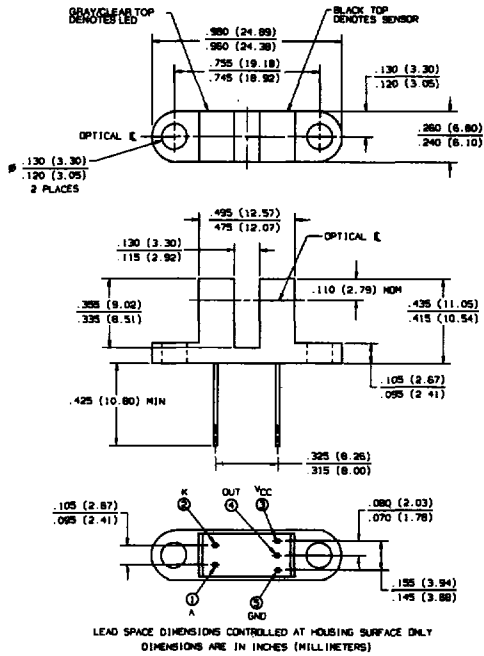

Package L

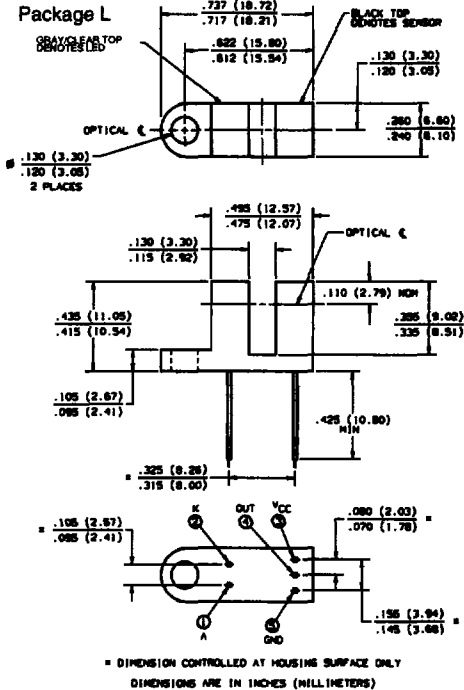

Package P

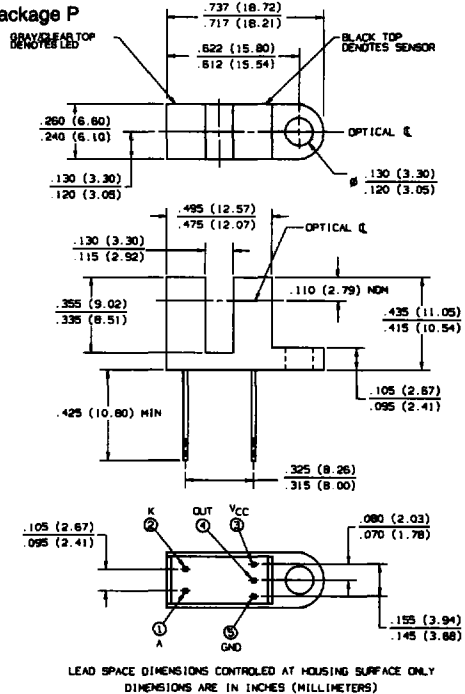

Optek reserves the right to make changes at any time in order to improve design and to supply the best product possible.

Optek Technology, Inc. 1215 W. Crosby Road Carrollton, Texas 75006 (972)323-2200 Fax (972)323-2396

Types OPB460, OPB470 "55" Series



Electrical Characteristics ($T_A = -40^\circ\text{C}$ to $+85^\circ\text{C}$ unless otherwise noted)

SYMBOL	PARAMETER	MIN	TYP	MAX	UNITS	TEST CONDITIONS
Input Diode						
V_F	Forward Voltage			1.7	V	$I_F = 20\text{ mA}$, $T_A = 25^\circ\text{C}$
I_R	Reverse Current			100	μA	$V_R = 2\text{ V}$, $T_A = 25^\circ\text{C}$
Output Photologic[®] Sensor						
V_{CC}	Operating D.C. Supply Voltage	4.5		16.0	V	
I_{CCL}	Low Level Supply Current: Buffered with 10 k pull-up Buffered Open-Collector Output			7.5	mA	$V_{CC} = 16\text{ V}$, $I_F = 0\text{ mA}^{(6)}$
	Inverted with 10 k pull-up Inverted Open-Collector Output			7.5	mA	$V_{CC} = 16\text{ V}$, $I_F = 4\text{ mA}$
I_{CCH}	High Level Supply Current: Buffered with 10 k pull-up Buffered Open-Collector Output			7.5	mA	$V_{CC} = 16\text{ V}$, $I_F = 4\text{ mA}$
	Inverted with 10 k pull-up Inverted Open-Collector Output			7.5	mA	$V_{CC} = 16\text{ V}$, $I_F = 0\text{ mA}^{(6)}$
V_{OL}	Low Level Output Voltage: Buffered with 10 k pull-up Buffered Open-Collector Output			0.4	V	$V_{CC} = 4.5\text{ V}$, $I_{OL} = 16\text{ mA}$ $I_F = 0\text{ mA}^{(6)}$
	Inverted with 10 k pull-up Inverted Open-Collector Output			0.4	V	$V_{CC} = 4.5\text{ V}$, $I_{OL} = 16\text{ mA}$ $I_F = 4\text{ mA}$
V_{OH}	High Level Output Voltage: Buffered with 10 k pull-up	$V_{CC}-1.5$			V	$V_{CC} = 4.5\text{ V}$ to 16 V , $I_{OH} = -800\text{ }\mu\text{A}$ $I_F = 4\text{ mA}$
	Inverted with 10 k pull-up	$V_{CC}-1.5$			V	$V_{CC} = 4.5\text{ V}$ to 16 V , $I_{OH} = -800\text{ }\mu\text{A}$ $I_F = 0\text{ mA}^{(6)}$
I_{OH}	High Level Output Current: Buffered Open-Collector Output			10	μA	$V_{CC} = 16\text{ V}$, $V_{OH} = 30\text{ V}$, $I_F = 4\text{ mA}$, $T_A = 25^\circ\text{C}$
	Inverted Open-Collector Output			10	μA	$V_{CC} = 16\text{ V}$, $V_{OH} = 30\text{ V}$, $I_F = 0\text{ mA}^{(6)}$, $T_A = 25^\circ\text{C}$
$I_F(+)$	LED Positive-Going Threshold Current			4	mA	$V_{CC} = 5\text{ V}$, $T_A = 25^\circ\text{C}$
$I_F(+)/I_F(-)$	Hysteresis		1.2			$V_{CC} = 5\text{ V}$
t_r, t_f	Output Rise Time, Output Fall Time		50		ns	$V_{CC} = 5\text{ V}$, $T_A = 25^\circ\text{C}$ $I_F = 0$ or 4 mA
t_{PLH}, t_{PHL}	Propagation Delay Low-High & High-Low		3.0		μs	$R_L = 300\text{ }\Omega$ to 5 V $C_L = 50\text{ pF}$

Types OPB460, OPB470 "51" Series

Electrical Characteristics ($T_A = -40^\circ\text{C}$ to $+85^\circ\text{C}$ unless otherwise noted)

SYMBOL	PARAMETER	MIN	TYP	MAX	UNITS	TEST CONDITIONS
Input Diode						
V_F	Forward Voltage			1.7	V	$I_F = 20\text{ mA}$, $T_A = 25^\circ\text{C}$
I_R	Reverse Current			100	μA	$V_R = 2\text{ V}$, $T_A = 25^\circ\text{C}$
Output Photologic[®] Sensor						
V_{CC}	Operating D.C. Supply Voltage	4.5		16.0	V	
I_{CCL}	Low Level Supply Current: Buffered with 10 k pull-up Buffered Open-Collector Output			7.5	mA	$V_{CC} = 16\text{ V}$, $I_F = 0\text{ mA}^{(6)}$
	Inverted with 10 k pull-up Inverted Open-Collector Output			7.5	mA	$V_{CC} = 16\text{ V}$, $I_F = 8\text{ mA}$
I_{CCH}	High Level Supply Current: Buffered with 10 k pull-up Buffered Open-Collector Output			7.5	mA	$V_{CC} = 16\text{ V}$, $I_F = 8\text{ mA}$
	Inverted with 10 k pull-up Inverted Open-Collector Output			7.5	mA	$V_{CC} = 16\text{ V}$, $I_F = 0\text{ mA}^{(6)}$
V_{OL}	Low Level Output Voltage: Buffered with 10 k pull-up Buffered Open-Collector Output			0.4	V	$V_{CC} = 4.5\text{ V}$, $I_{OL} = 16\text{ mA}$ $I_F = 0\text{ mA}^{(6)}$
	Inverted with 10 k pull-up Inverted Open-Collector Output			0.4	V	$V_{CC} = 4.5\text{ V}$, $I_{OL} = 16\text{ mA}$ $I_F = 8\text{ mA}$
V_{OH}	High Level Output Voltage: Buffered with 10 k pull-up	$V_{CC}-1.5$			V	$V_{CC} = 4.5\text{ V}$ to 16 V , $I_{OH} = -800\text{ }\mu\text{A}$ $I_F = 8\text{ mA}$
	Inverted with 10 k pull-up	$V_{CC}-1.5$			V	$V_{CC} = 4.5\text{ V}$ to 16 V , $I_{OH} = -800\text{ }\mu\text{A}$ $I_F = 0\text{ mA}^{(6)}$
I_{OH}	High Level Output Current: Buffered Open-Collector Output			10	μA	$V_{CC} = 16\text{ V}$, $V_{OH} = 30\text{ V}$, $I_F = 8\text{ mA}$, $T_A = 25^\circ\text{C}$
	Inverted Open-Collector Output			10	μA	$V_{CC} = 16\text{ V}$, $V_{OH} = 30\text{ V}$, $I_F = 0\text{ mA}^{(6)}$, $T_A = 25^\circ\text{C}$
$I_F(+)$	LED Positive-Going Threshold Current			8	mA	$V_{CC} = 5\text{ V}$, $T_A = 25^\circ\text{C}$
$I_F(+)/I_F(-)$	Hysteresis		1.2			$V_{CC} = 5\text{ V}$
t_r, t_f	Output Rise Time, Output Fall Time		50		ns	$V_{CC} = 5\text{ V}$, $T_A = 25^\circ\text{C}$ $I_F = 0$ or 8 mA
t_{PLH}, t_{PHL}	Propagation Delay Low-High & High-Low		3.0		μs	$R_L = 300\text{ }\Omega$ to 5 V $C_L = 50\text{ pF}$

Optek reserves the right to make changes at any time in order to improve design and to supply the best product possible.

Optek Technology, Inc. 1215 W. Crosby Road Carrollton, Texas 75006 (972)323-2200 Fax (972)323-2396

Types OPB460, OPB470 "11" Series



Electrical Characteristics ($T_A = -40^\circ\text{C}$ to $+85^\circ\text{C}$ unless otherwise noted)

SYMBOL	PARAMETER	MIN	TYP	MAX	UNITS	TEST CONDITIONS
Input Diode						
V_F	Forward Voltage			1.7	V	$I_F = 20\text{ mA}$, $T_A = 25^\circ\text{C}$
I_R	Reverse Current			100	μA	$V_R = 2\text{ V}$, $T_A = 25^\circ\text{C}$
Output Photologic[®] Sensor						
V_{CC}	Operating D.C. Supply Voltage	4.5		16.0	V	
I_{CCL}	Low Level Supply Current: Buffered with 10 k pull-up Buffered Open-Collector Output			7.5	mA	$V_{CC} = 16\text{ V}$, $I_F = 0\text{ mA}^{(6)}$
	Inverted with 10 k pull-up Inverted Open-Collector Output			7.5	mA	$V_{CC} = 16\text{ V}$, $I_F = 12\text{ mA}$
I_{CCH}	High Level Supply Current: Buffered with 10 k pull-up Buffered Open-Collector Output			7.5	mA	$V_{CC} = 16\text{ V}$, $I_F = 12\text{ mA}$
	Inverted with 10 k pull-up Inverted Open-Collector Output			7.5	mA	$V_{CC} = 16\text{ V}$, $I_F = 0\text{ mA}^{(6)}$
V_{OL}	Low Level Output Voltage: Buffered with 10 k pull-up Buffered Open-Collector Output			0.4	V	$V_{CC} = 4.5\text{ V}$, $I_{OL} = 16\text{ mA}$ $I_F = 0\text{ mA}$
	Inverted with 10 k pull-up Inverted Open-Collector Output			0.4	V	$V_{CC} = 4.5\text{ V}$, $I_{OL} = 16\text{ mA}$ $I_F = 12\text{ mA}^{(6)}$
V_{OH}	High Level Output Voltage: Buffered with 10 k pull-up	$V_{CC}-1.5$			V	$V_{CC} = 4.5\text{ V to }16\text{ V}$, $I_{OH} = -800\text{ }\mu\text{A}$ $I_F = 12\text{ mA}$
	Inverted with 10 k pull-up	$V_{CC}-1.5$			V	$V_{CC} = 4.5\text{ V to }16\text{ V}$, $I_{OH} = -800\text{ }\mu\text{A}$ $I_F = 0\text{ mA}^{(6)}$
I_{OH}	High Level Output Current: Buffered Open-Collector Output			10	μA	$V_{CC} = 16\text{ V}$, $V_{OH} = 30\text{ V}$, $I_F = 12\text{ mA}$, $T_A = 25^\circ\text{C}$
	Inverted Open-Collector Output			10	μA	$V_{CC} = 16\text{ V}$, $V_{OH} = 30\text{ V}$, $I_F = 0\text{ mA}^{(6)}$, $T_A = 25^\circ\text{C}$
$I_{F(+)}$	LED Positive-Going Threshold Current			12	mA	$V_{CC} = 5\text{ V}$, $T_A = 25^\circ\text{C}$
$I_{F(+)} / I_{F(-)}$	Hysteresis		1.2			$V_{CC} = 5\text{ V}$
t_r, t_f	Output Rise Time, Output Fall Time		50		ns	$V_{CC} = 5\text{ V}$, $T_A = 25^\circ\text{C}$ $I_F = 0$ or 12 mA
t_{PLH}, t_{PHL}	Propagation Delay Low-High & High-Low		3.0		μs	$R_L = 300\text{ }\Omega$ to 5 V $C_L = 50\text{ pF}$

Types OPB460, OPB470 Series

PART NUMBER GUIDE

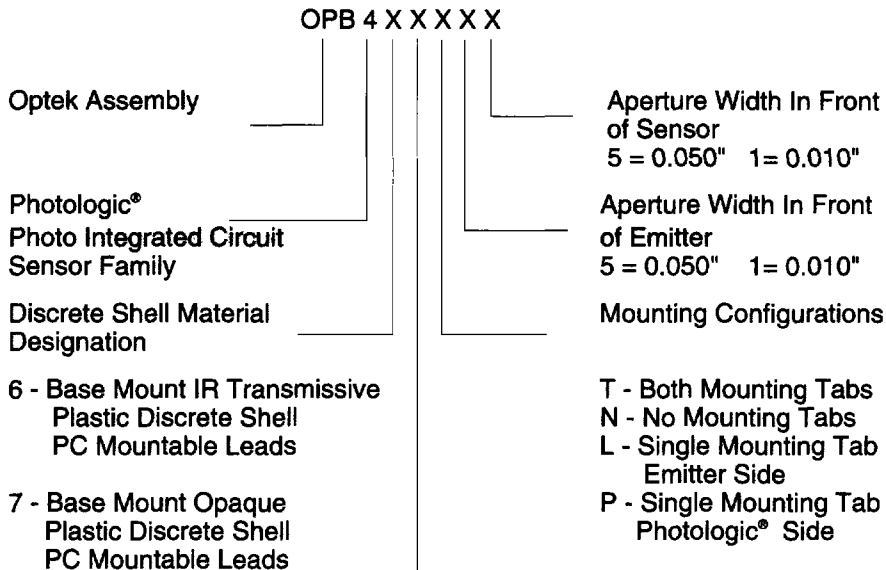

Electrical Specification Variations

- 0 - Buffered with 10 k pull-up
- 1 - Buffered Open-Collector Output
- 2 - Inverted with 10 k pull-up
- 3 - Inverted Open-Collector Output

Schematics

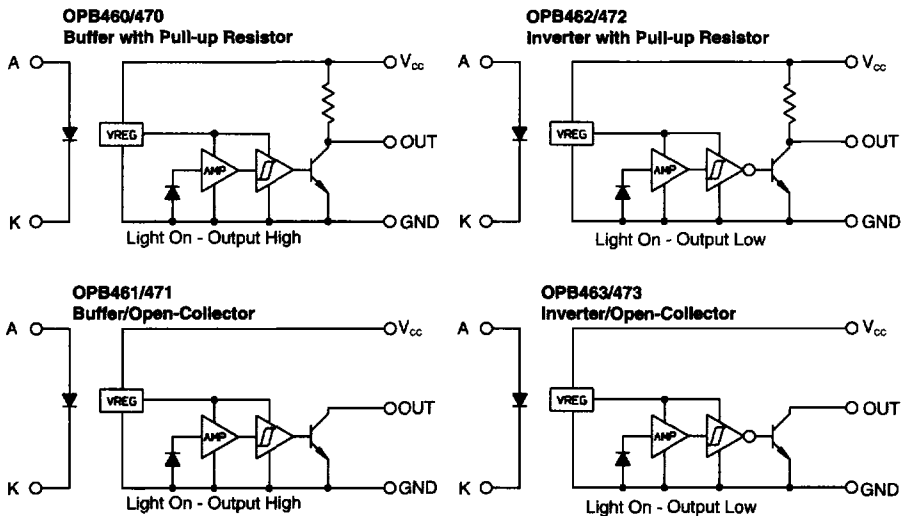

Optek reserves the right to make changes at any time in order to improve design and to supply the best product possible.

Optek Technology, Inc. 1215 W. Crosby Road Carrollton, Texas 75006 (972)323-2200 Fax (972)323-2396